

3-TERMINAL 1A POSITIVE VOLTAGE REGULATORS

The LM78XX series of three-terminal positive regulators, – fixed output voltage and TO-220 package – are designed for a wide range of applications.

These applications include on-card regulation for elimination of noise and distribution problems associated with single point regulation. In addition, they can be used with power pass elements to make high current voltage regulators.

If adequate heat sinking is provided, each of these regulators can deliver up to 1A of output current.

Although designed primarily as fixed voltage regulators, these devices can be used with external components to obtain adjustable voltage and currents.

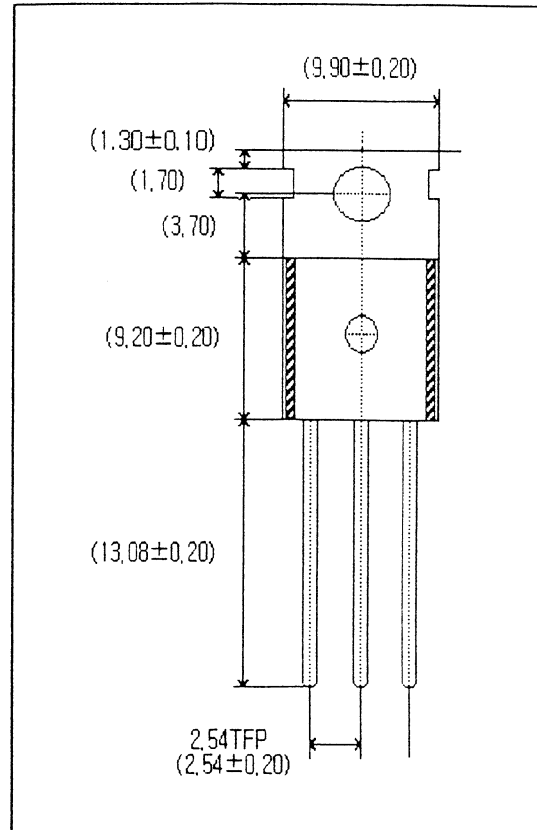

FEATURES

- ◇ Output current in excess of 1A
- ◇ No external components required
- ◇ Internal short circuit current limiting
- ◇ Internal thermal overload protection
- ◇ Output transistor safe-area compensation
- ◇ Output voltage offered in 4% tolerance

ABSOLUTE MAXIMUM RATINGS

Characteristic		Symbol	Value	Unit
Input Voltage	LM7805 ~ LM7818	V_i	35	V
	LM7824		40	
Operating junction temperature		T_{opr}	0 ~ +150	°C
Operating temperature		T_{opr}	0 ~ +125	
Storage temperature		T_{stg}	-65 ~ +150	

For more information, or to purchase call 1-800-214-8769

1. BLOCK DIAGRAM

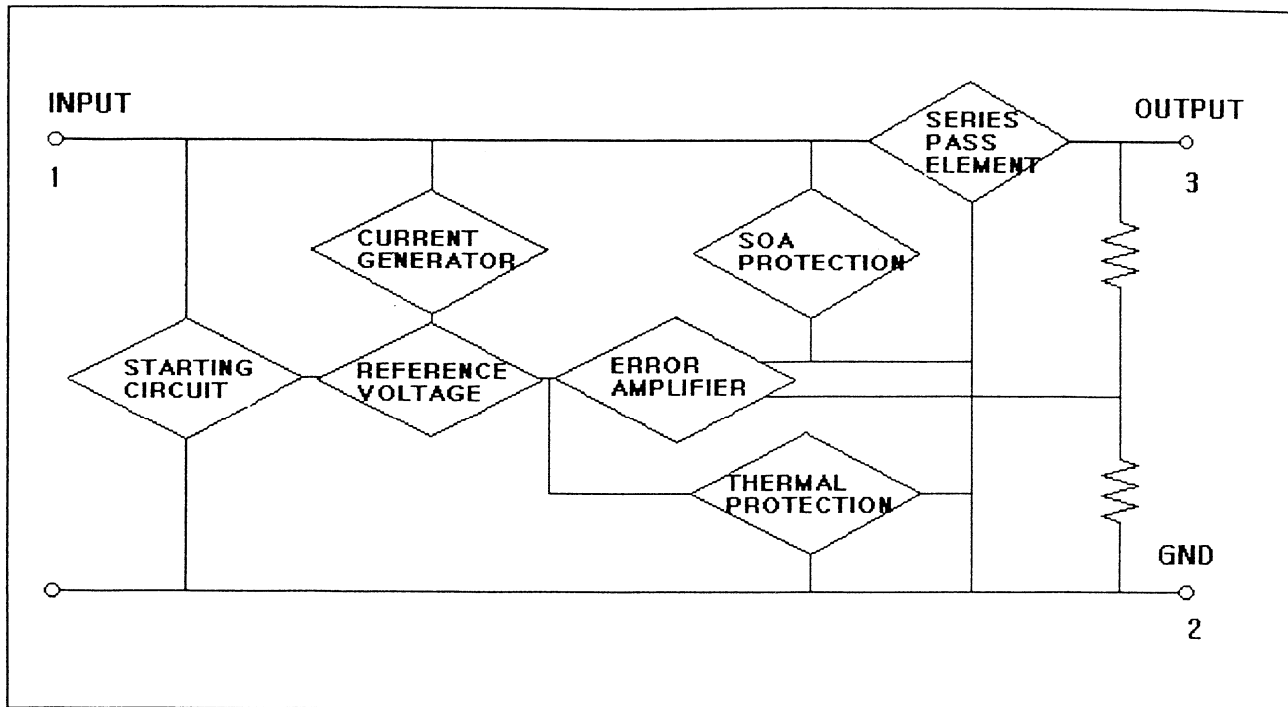

2. TYPICAL APPLICATIONS

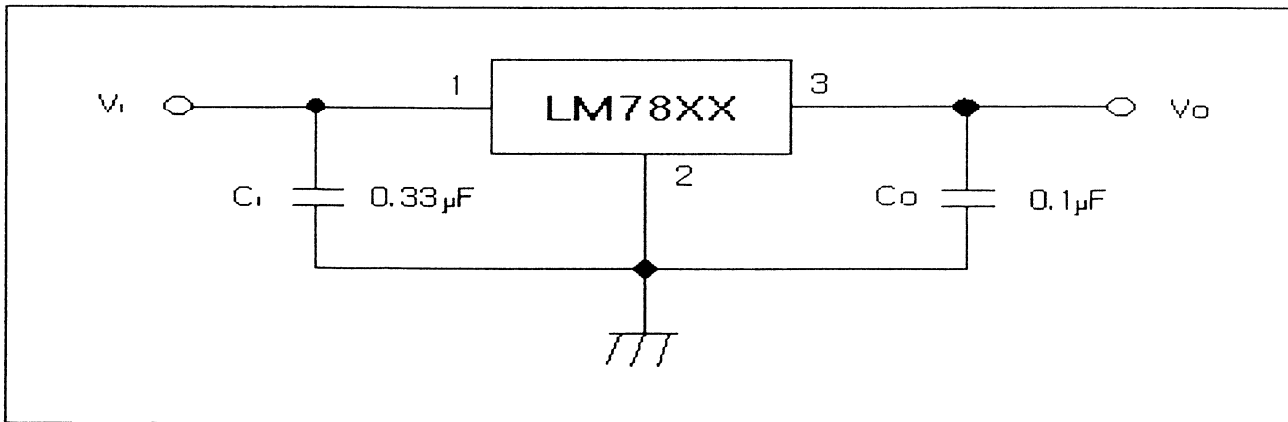

Notes :

- (1) To specify an output voltage, substitute voltage value for "XX"
- (2) C_i is required if regulator is located in appreciable distance from power supply filter.
- (3) C_o improves stability and transient response.

For more information, or to purchase call 1-800-214-8769

LM7805 ELECTRICAL CHARACTERISTICS

(Refer to test circuit, $T_{MIN} < T_J < T_{MAX}$, $I_o = 500\text{mA}$, $V_i = 10\text{V}$, $C_i = 0.33\mu\text{F}$, $C_o = 0.1\mu\text{F}$, unless otherwise specified)

Characteristic	Symbol	Test condition	Min.	Typ.	Max.	Unit
Output Voltage	V_o	$T_J = 25^\circ\text{C}$	4.8	5.0	5.2	V
		$5.0\text{mA} \leq I_o \leq 1.0\text{A}$, $P_o \leq 15\text{W}$ $V_i = 7\text{V to } 20\text{V}$ $V_i = 8\text{V to } 20\text{V}$	4.75	5.0	5.25	
Line Regulation	ΔV_o	$T_J = 25^\circ\text{C}$	$V_o = 7\text{V to } 25\text{V}$	4.0	100	mV
			$V_i = 8\text{V to } 12\text{V}$	1.6	50	
Load Regulation	ΔV_o	$T_J = 25^\circ\text{C}$	$I_o = 5.0\text{mA to } 1.5\text{A}$	9	100	mV
			$I_o = 250\text{mA to } 750\text{mA}$	4	50	
Quiescent Current	I_q	$T_J = 25^\circ\text{C}$		5	8	mA
Quiescent Current Change	ΔI_q		$I_o = 5\text{mA to } 1\text{A}$	0.03	0.5	mA
			$V_i = 7\text{V to } 25\text{V}$	0.3	1.3	
			$V_i = 8\text{V to } 25\text{V}$			
Output Voltage Drift	$\Delta V_o / \Delta T$	$I_o = 5\text{mA}$		-0.8		mV/ $^\circ\text{C}$
Output Noise Voltage	V_N	$f = 10\text{Hz to } 100\text{KHz}$, $T_A = 25^\circ\text{C}$		42		μV
Ripple Rejection	RR	$f = 120\text{Hz}$ $V_o = 8\text{V to } 18\text{V}$	62	73		dB
Dropout Voltage	V_D	$I_o = 1\text{A}$, $T_J = 25^\circ\text{C}$		2		V
Peak Current	I_{PK}	$T_J = 25^\circ\text{C}$		2.2		A
Output Resistance	R_o	$f = 1\text{KHz}$		15		$\text{M}\Omega$
Short Circuit Current	I_{sc}	$V_i = 35\text{V}$, $T_A = 25^\circ\text{C}$		230		mA

Notes

* $T_{MIN} < T_J < T_{MAX}$ LM78XX ; $T_{MIN} = 0^\circ\text{C}$, $T_{MAX} = 125^\circ\text{C}$ * Load and line regulation are specified at constant junction temperature. Changes in V_o due to heating effects must be taken into account separately. Pulse testing with low duty is used.

For more information, or to purchase call 1-800-214-8769

LM7806 ELECTRICAL CHARACTERISTICS

(Refer to test circuit, $T_{MIN} < T_J < T_{MAX}$, $I_O = 500\text{mA}$, $V_I = 11\text{V}$, $C_I = 0.33\mu\text{F}$, $C_O = 0.1\mu\text{F}$, unless otherwise specified)

Characteristic	Symbol	Test condition	Min.	Typ.	Max.	Unit
Output Voltage	V_O	$T_J = 25^\circ\text{C}$	5.75	6.0	6.25	V
		$5.0\text{mA} \leq I_O \leq 1.0\text{A}$, $P_O \leq 15\text{W}$ $V_I = 8.0\text{V to } 21\text{V}$ $V_I = 9.0\text{V to } 21\text{V}$	5.7	6.0	6.3	
Line Regulation	ΔV_O	$T_J = 25^\circ\text{C}$	$V_O = 8\text{V to } 25\text{V}$	5	120	mV
			$V_I = 9\text{V to } 13\text{V}$	1.5	60	
Load Regulation	ΔV_O	$T_J = 25^\circ\text{C}$	$I_O = 5\text{mA to } 1.5\text{A}$	9	120	mV
			$I_O = 250\text{mA to } 750\text{mA}$	3	60	
Quiescent Current	I_Q	$T_J = 25^\circ\text{C}$		5	8	mA
Quiescent Current Change	ΔI_Q	$T_J = 25^\circ\text{C}$	$I_O = 5\text{mA to } 1\text{A}$		0.5	mA
			$V_I = 8\text{V to } 25\text{V}$		1.3	
			$\dot{V}_I = 9\text{V to } 25\text{V}$			
Output Voltage Drift	$\Delta V_O / \Delta T$	$I_O = 5\text{mA}$		-0.8		mV/ $^\circ\text{C}$
Output Noise Voltage	V_N	$f = 10\text{Hz to } 100\text{KHz}$, $T_A = 25^\circ\text{C}$		45		μV
Ripple Rejection	RR	$f = 120\text{Hz}$ $V_I = 9\text{V to } 19\text{V}$	59	75		dB
Dropout Voltage	V_D	$I_O = 1\text{A}$, $T_J = 25^\circ\text{C}$		2		V
Peak Current	I_{PK}	$T_J = 25^\circ\text{C}$		2.2		A
Output Resistance	R_O	$f = 1\text{KHz}$		19		$\text{m}\Omega$
Short Circuit Current	I_{SC}	$V_I = 35\text{V}$, $T_A = 25^\circ\text{C}$		250		mA

Notes

* $T_{MIN} < T_J < T_{MAX}$ LM78XX ; $T_{MIN} = 0^\circ\text{C}$, $T_{MAX} = 125^\circ\text{C}$ * Load and line regulation are specified at constant junction temperature. Changes in V_O due to heating effects must be taken into account separately. Pulse testing with low duty is used.

For more information, or to purchase call 1-800-214-8769

LM7808 ELECTRICAL CHARACTERISTICS

(Refer to test circuit, $T_{MIN} < T_J < T_{MAX}$, $I_o = 500\text{mA}$, $V_i = 14\text{V}$, $C_i = 0.33\mu\text{F}$, $C_o = 0.1\mu\text{F}$, unless otherwise specified)

Characteristic	Symbol	Test condition	Min.	Typ.	Max.	Unit
Output Voltage	V_o	$T_J = 25^\circ\text{C}$	7.7	8.0	8.3	V
		$5.0\text{mA} \leq I_o \leq 1.0\text{A}$, $P_o \leq 15\text{W}$	7.6	8.0	8.4	
		$V_i = 10.5\text{V to } 23\text{V}$ $V_i = 11.5\text{V to } 23\text{V}$				
Line Regulation	ΔV_o	$T_J = 25^\circ\text{C}$	$V_i = 10.5\text{V to } 25\text{V}$	5.0	160	mV
			$V_i = 11.5\text{V to } 17\text{V}$	2.0	80	
Load Regulation	ΔV_o	$T_J = 25^\circ\text{C}$	$I_o = 5.0\text{mA to } 1.5\text{A}$	10	160	mV
			$I_o = 250\text{mA to } 750\text{mA}$	5	80	
Quiescent Current	I_q	$T_J = 25^\circ\text{C}$		5	8	mA
Quiescent Current Change	ΔI_q		$I_o = 5\text{mA to } 1\text{A}$	0.05	0.5	mA
			$V_i = 10.5\text{V to } 25\text{V}$	0.5	1.0	
			$V_i = 11.5\text{V to } 25\text{V}$			
Output Voltage Drift	$\Delta V_o / \Delta T$	$I_o = 5\text{mA}$		-0.8		mV/°C
Output Noise Voltage	V_N	$f = 10\text{Hz to } 100\text{KHz}$, $T_A = 25^\circ\text{C}$		52		μV
Ripple Rejection	RR	$f = 120\text{Hz}$, $V_i = 11.5\text{V to } 21.5\text{V}$	56	73		dB
Dropout Voltage	V_D	$I_o = 1\text{A}$, $T_J = 25^\circ\text{C}$		2		V
Peak Current	I_{PK}	$T_J = 25^\circ\text{C}$		2.2		A
Output Resistance	R_o	$f = 1\text{KHz}$		17		$\text{M}\Omega$
Short Circuit Current	I_{SC}	$V_i = 35\text{V}$, $T_J = 25^\circ\text{C}$		230		mA

Notes

* $T_{MIN} < T_J < T_{MAX}$ LM78XX ; $T_{MIN} = 0^\circ\text{C}$, $T_{MAX} = 125^\circ\text{C}$ * Load and line regulation are specified at constant junction temperature. Changes in V_o due to heating effects must be taken into account separately. Pulse testing with low duty is used.

For more information, or to purchase call 1-800-214-8769

LM7809 ELECTRICAL CHARACTERISTICS

(Refer to test circuit, $T_{MIN} < T_J < T_{MAX}$, $I_o = 500\text{mA}$, $V_i = 15\text{V}$, $C_i = 0.33\mu\text{F}$, $C_o = 0.1\mu\text{F}$, unless otherwise specified)

Characteristic	Symbol	Test condition	Min.	Typ.	Max.	Unit	
Output Voltage	V_o	$T_J = 25^\circ\text{C}$	8.65	9.0	9.35	V	
		$5.0\text{mA} \leq I_o \leq 1.0\text{A}$, $P_d \leq 15\text{W}$ $V_i = 11.5\text{V to } 24\text{V}$ $V_i = 12.5\text{V to } 24\text{V}$	8.6	9.0	9.4		
Line Regulation	ΔV_o	$T_J = 25^\circ\text{C}$	$V_i = 11.5\text{V to } 25\text{V}$		6.0	180	mV
			$V_i = 12\text{V to } 25\text{V}$		2	90	
Load Regulation	ΔV_o	$T_J = 25^\circ\text{C}$	$I_o = 5\text{mA to } 1.5\text{A}$		12	180	mV
			$I_o = 250\text{mA to } 750\text{mA}$		4	90	
Quiescent Current	I_o	$T_J = 25^\circ\text{C}$		5.0	8	mA	
Quiescent Current Chang	ΔI_o		$I_o = 5\text{mA to } 1\text{A}$			0.5	mA
			$V_i = 11.5\text{V to } 26\text{V}$			1.3	
			$V_i = 12.5\text{V to } 26\text{V}$				
Output Voltage Drift	$\Delta V_o / \Delta T$	$I_o = 5\text{mA}$		-1		mV/ $^\circ\text{C}$	
Output Noise Voltage	V_N	$f = 10\text{Hz to } 100\text{KHz}$, $T_A = 25^\circ\text{C}$		58		μV	
Ripple Rejection	RR	$f = 120\text{Hz}$ $V_i = 13\text{V to } 23\text{V}$	56	71		dB	
Dropout Voltage	V_d	$I_o = 1\text{A}$, $T_J = 25^\circ\text{C}$		2		V	
Peak Current	I_{PK}	$T_J = 25^\circ\text{C}$		2.2		A	
Output Resistance	R_o	$f = 1\text{KHz}$		17		$\text{M}\Omega$	
Short Circuit Current	I_{sc}	$V_i = 35\text{V}$, $T_J = 25^\circ\text{C}$		250		mA	

Notes

* $T_{MIN} < T_J < T_{MAX}$

LM78XX ; $T_{MIN} = 0^\circ\text{C}$, $T_{MAX} = 125^\circ\text{C}$

* Load and line regulation are specified at constant junction temperature. Changes in V_o due to heating effects must be taken into account separately. Pulse testing with low duty is used.

For more information, or to purchase call 1-800-214-8769

LM7810 ELECTRICAL CHARACTERISTICS

(Refer to test circuit, $T_{MIN} < T_J < T_{MAX}$, $I_O = 500\text{mA}$, $V_I = 16\text{V}$, $C_I = 0.33\mu\text{F}$, $C_O = 0.1\mu\text{F}$, unless otherwise specified)

Characteristic	Symbol	Test condition	Min.	Typ.	Max.	Unit	
Output Voltage	V_O	$T_J = 25^\circ\text{C}$	9.6	10.0	10.4	V	
		$5.0\text{mA} \leq I_O \leq 1.0\text{A}$, $P_D \leq 15\text{W}$					
		$V_I = 12.5\text{V to } 25\text{V}$ $V_I = 13.5\text{V to } 25\text{V}$	9.5	10	10.5		
Line Regulation	ΔV_O	$T_J = 25^\circ\text{C}$	$V_I = 12.5\text{V to } 25\text{V}$		10	200	mV
			$V_I = 13\text{V to } 25\text{V}$		3	100	
Load Regulation	ΔV_O	$T_J = 25^\circ\text{C}$	$I_O = 5\text{mA to } 1.5\text{A}$		12	200	mV
			$I_O = 250\text{mA to } 750\text{mA}$		4	400	
Quiescent Current	I_Q	$T_J = 25^\circ\text{C}$		5.1	8	mA	
Quiescent Current Change	ΔI_Q	$T_J = 25^\circ\text{C}$	$I_O = 5\text{mA to } 1.0\text{A}$			0.5	mA
			$V_I = 12.5\text{V to } 29\text{V}$			1	
			$V_I = 13.5\text{V to } 29\text{V}$				
Output Voltage Drift	$\Delta V_O / \Delta T$	$I_O = 5\text{mA}$		-1		mV/ $^\circ\text{C}$	
Output Noise Voltage	V_N	$f = 10\text{Hz to } 100\text{KHz}$, $T_A = 25^\circ\text{C}$		58		μV	
Ripple Rejection	RR	$f = 120\text{Hz}$ $V_I = 13\text{V to } 23\text{V}$	56	71		dB	
Dropout Voltage	V_D	$I_O = 1\text{A}$, $T_J = 25^\circ\text{C}$		2		V	
Peak Current	I_{PK}	$T_J = 25^\circ\text{C}$		2.2		A	
Output Resistance	R_O	$f = 1\text{KHz}$		17		$\text{M}\Omega$	
Short Circuit Current	I_{SC}	$V_I = 35\text{V}$, $T_J = 25^\circ\text{C}$		250		mA	

Notes

* $T_{MIN} < T_J < T_{MAX}$ LM78XX : $T_{MIN} = 0^\circ\text{C}$, $T_{MAX} = 125^\circ\text{C}$ * Load and line regulation are specified at constant junction temperature. Changes in V_O due to heating effects must be taken into account separately. Pulse testing with low duty is used.

For more information, or to purchase call 1-800-214-8769

LM7812 ELECTRICAL CHARACTERISTICS

(Refer to test circuit, $T_{MIN} < T_J < T_{MAX}$, $I_O = 500\text{mA}$, $V_I = 19\text{V}$, $C_I = 0.33\mu\text{F}$, $C_O = 0.1\mu\text{F}$, unless otherwise specified)

Characteristic	Symbol	Test condition	Min.	Typ.	Max.	Unit
Output Voltage	V_O	$T_J = 25^\circ\text{C}$	11.5	12	12.5	V
		$5.0\text{mA} \leq I_O \leq 1.0\text{A}$, $P_D \leq 15\text{W}$ $V_I = 14.5\text{V to } 27\text{V}$ $V_I = 15.5\text{V to } 27\text{V}$	11.4	12	12.6	
Line Regulation	ΔV_O	$T_J = 25^\circ\text{C}$	$V_I = 14.5\text{V to } 30\text{V}$	10	240	mV
			$V_I = 16\text{V to } 22\text{V}$	3	120	
Load Regulation	ΔV_O	$T_J = 25^\circ\text{C}$	$I_O = 5\text{mA to } 1.5\text{A}$	11	240	mV
			$I_O = 250\text{mA to } 750\text{mA}$	5	120	
Quiescent Current	I_Q	$T_J = 25^\circ\text{C}$		5.1	8	mA
Quiescent Current Chang	ΔI_Q		$I_O = 5\text{mA to } 1\text{A}$	0.1	0.5	mA
			$V_I = 14.5\text{V to } 30\text{V}$ $V_I = 15\text{V to } 30\text{V}$	0.5	1.0	
Output Voltage Drift	$\Delta V_O / \Delta T$	$I_O = 5\text{mA}$		-1		mV/ $^\circ\text{C}$
Output Noise Voltage	V_N	$f = 10\text{Hz to } 100\text{KHz}$, $T_A = 25^\circ\text{C}$		76		μV
Ripple Rejection	RR	$f = 120\text{Hz}$ $V_I = 15\text{V to } 25\text{V}$	55	71		dB
Dropout Voltage	V_D	$I_O = 1\text{A}$, $T_J = 25^\circ\text{C}$		2		V
Peak Current	I_{PK}	$T_J = 25^\circ\text{C}$		2.2		A
Output Resistance	R_O	$f = 1\text{KHz}$		18		$\text{M}\Omega$
Short Circuit Current	I_{SC}	$V_I = 35\text{V}$, $T_J = 25^\circ\text{C}$		230		mA

Notes

* $T_{MIN} < T_J < T_{MAX}$

LM78XX ; $T_{MIN} = 0^\circ\text{C}$, $T_{MAX} = 125^\circ\text{C}$

* Load and line regulation are specified at constant junction temperature. Changes in V_O due to heating effects must be taken into account separately. Pulse testing with low duty is used.

For more information, or to purchase call 1-800-214-8769

LM7815 ELECTRICAL CHARACTERISTICS

(Refer to test circuit, $T_{MIN} < T_J < T_{MAX}$, $I_O = 500\text{mA}$, $V_I = 23\text{V}$, $C_I = 0.33\mu\text{F}$, $C_O = 0.1\mu\text{F}$, unless otherwise specified)

Characteristic	Symbol	Test condition		Min.	Typ.	Max.	Unit
Output Voltage	V_O	$T_J = 25^\circ\text{C}$		14.4	15	15.6	V
		$5.0\text{mA} \leq I_O \leq 1.0\text{A}$, $P_O \leq 15\text{W}$		14.25	15	15.75	
		$V_I = 17.5\text{V to } 30\text{V}$					
		$V_I = 18.5\text{V to } 30\text{V}$					
Line Regulation	ΔV_O	$T_J = 25^\circ\text{C}$	$V_I = 17.5\text{V to } 30\text{V}$		11	300	mV
			$V_I = 20\text{V to } 26\text{V}$		3	150	
Load Regulation	ΔV_O	$T_J = 25^\circ\text{C}$	$I_O = 5\text{mA to } 1.5\text{A}$		12	300	mV
			$I_O = 250\text{mA to } 750\text{mA}$		4	150	
Quiescent Current	I_Q	$T_J = 25^\circ\text{C}$			5.2	8	mA
Quiescent Current Change	ΔI_Q	$I_O = 5\text{mA to } 1\text{A}$				0.5	mA
		$V_I = 17.5\text{V to } 30\text{V}$				1.0	
		$V_I = 18.5\text{V to } 30\text{V}$					
Output Voltage Drift	$\Delta V_O / \Delta T$	$I_O = 5\text{mA}$			-1		mV/ $^\circ\text{C}$
Output Noise Voltage	V_N	$f = 10\text{Hz to } 100\text{KHz}$, $T_A = 25^\circ\text{C}$			90		μV
Ripple Rejection	RR	$f = 120\text{Hz}$		54	70		dB
		$V_I = 18.5\text{V to } 28.5\text{V}$					
Dropout Voltage	V_D	$I_O = 1\text{A}$, $T_J = 25^\circ\text{C}$			2		V
Peak Current	I_{PK}	$T_J = 25^\circ\text{C}$			2.2		A
Output Resistance	R_O	$f = 1\text{KHz}$			19		$\text{m}\Omega$
Short Circuit Current	I_{SC}	$V_I = 35\text{V}$, $T_A = 25^\circ\text{C}$			250		mA

Notes

* $T_{MIN} < T_J < T_{MAX}$ LM78XX : $T_{MIN} = 0^\circ\text{C}$, $T_{MAX} = 125^\circ\text{C}$ * Load and line regulation are specified at constant junction temperature. Changes in V_O due to heating effects must be taken into account separately. Pulse testing with low duty is used.

For more information, or to purchase call 1-800-214-8769

LM7818 ELECTRICAL CHARACTERISTICS

(Refer to test circuit, $T_{MIN} < T_J < T_{MAX}$, $I_o = 500\text{mA}$, $V_i = 27\text{V}$, $C_i = 0.33\mu\text{F}$, $C_o = 0.1\mu\text{F}$, unless otherwise specified)

Characteristic	Symbol	Test condition	Min.	Typ.	Max.	Unit	
Output Voltage	V_o	$T_J = 25^\circ\text{C}$	17.3	18	18.7	V	
		$5.0\text{mA} \leq I_o \leq 1.0\text{A}$, $P_D \leq 15\text{W}$ $V_i = 21\text{V to } 33\text{V}$ $V_i = 22\text{V to } 33\text{V}$	17.1	18	18.9		
Line Regulation	ΔV_o	$T_J = 25^\circ\text{C}$	$V_i = 21\text{V to } 33\text{V}$		15	360	mV
			$V_i = 24\text{V to } 30\text{V}$		5	180	
Load Regulation	ΔV_o	$T_J = 25^\circ\text{C}$	$I_o = 5\text{mA to } 1.5\text{A}$		15	360	mV
			$I_o = 250\text{mA to } 750\text{mA}$		5	180	
Quiescent Current	I_q	$T_J = 25^\circ\text{C}$		5.2	8	mA	
Quiescent Current Change	ΔI_q		$I_o = 5\text{mA to } 1\text{A}$			0.5	mA
			$V_i = 21\text{V to } 33\text{V}$			1	
			$V_i = 22\text{V to } 33\text{V}$				
Output Voltage Drift	$\Delta V_o / \Delta T$	$I_o = 5\text{mA}$		-1		mV/°C	
Output Noise Voltage	V_N	$f = 10\text{Hz to } 100\text{KHz}$, $T_A = 25^\circ\text{C}$		110		μV	
Ripple Rejection	RR	$f = 120\text{Hz}$ $V_i = 22\text{V to } 32\text{V}$	53	69		dB	
Dropout Voltage	V_D	$I_o = 1\text{A}$, $T_J = 25^\circ\text{C}$		2		V	
Peak Current	I_{PK}	$T_J = 25^\circ\text{C}$		2.2		A	
Output Resistance	R_o	$f = 1\text{KHz}$		22		$\text{M}\Omega$	
Short Circuit Current	I_{SC}	$V_i = 35\text{V}$, $T_A = 25^\circ\text{C}$		250		mA	

Notes

* $T_{MIN} < T_J < T_{MAX}$

LM78XX : $T_{MIN} = 0^\circ\text{C}$, $T_{MAX} = 125^\circ\text{C}$

* Load and line regulation are specified at constant junction temperature. Changes in V_o due to heating effects must be taken into account separately. Pulse testing with low duty is used.

For more information, or to purchase call 1-800-214-8769

LM7824 ELECTRICAL CHARACTERISTICS

(Refer to test circuit, $T_{MIN} < T_J < T_{MAX}$, $I_o = 500\text{mA}$, $V_i = 33\text{V}$, $C_i = 0.33\mu\text{F}$, $C_o = 0.1\mu\text{F}$, unless otherwise specified)

Characteristic	Symbol	Test condition	Min.	Typ.	Max.	Unit
Output Voltage	V_o	$T_J = 25^\circ\text{C}$	23	24	25	V
		$5.0\text{mA} \leq I_o \leq 1.0\text{A}$, $P_o \leq 15\text{W}$				
		$V_i = 27\text{V to } 38\text{V}$ $V_i = 28\text{V to } 38\text{V}$	22.8	24	25.25	
Line Regulation	ΔV_o	$T_J = 25^\circ\text{C}$	$V_i = 27\text{V to } 38\text{V}$	17	480	mV
			$V_i = 30\text{V to } 36\text{V}$	6	240	
Load Regulation	ΔV_o	$T_J = 25^\circ\text{C}$	$I_o = 5\text{mA to } 1.5\text{A}$	15	480	mV
			$I_o = 250\text{mA to } 750\text{mA}$	5	240	
Quiescent Current	I_q	$T_J = 25^\circ\text{C}$		5.2	8	mA
Quiescent Current Change	ΔI_q		$I_o = 5\text{mA to } 1\text{A}$	0.1	0.5	mA
			$V_i = 27\text{V to } 38\text{V}$	0.5	1	
			$V_i = 28\text{V to } 38\text{V}$			
Output Voltage Drift	$\Delta V_o / \Delta T$	$I_o = 5\text{mA}$		-1.5		mV/ $^\circ\text{C}$
Output Noise Voltage	V_N	$f = 10\text{Hz to } 100\text{KHz}$, $T_A = 25^\circ\text{C}$		60		μV
Ripple Rejection	RR	$f = 120\text{Hz}$ $V_i = 28\text{V to } 38\text{V}$	50	67		dB
Dropout Voltage	V_D	$I_o = 1\text{A}$, $T_J = 25^\circ\text{C}$		2		V
Peak Current	I_{PK}	$T_J = 25^\circ\text{C}$		2.2		A
Output Resistance	R_o	$f = 1\text{KHz}$		28		$\text{M}\Omega$
Short Circuit Current	I_{sc}	$V_i = 35\text{V}$, $T_A = 25^\circ\text{C}$		230		mA

Notes

* $T_{MIN} < T_J < T_{MAX}$ LM78XX : $T_{MIN} = 0^\circ\text{C}$, $T_{MAX} = 125^\circ\text{C}$ * Load and line regulation are specified at constant junction temperature. Changes in V_o due to heating effects must be taken into account separately. Pulse testing with low duty is used.

For more information, or to purchase call 1-800-214-8769