

FIXED VOLTAGE REGULATOR

LM78LXX

3-TERMINAL 0.1A POSITIVE VOLTAGE REGULATORS

This series of fixed-voltage monolithic integrated-circuit voltage regulators is designed for a wide range of applications.

These applications include on-card regulation for elimination of noise and distribution problems associated with single-point regulation.

In addition, they can be used with power-pass elements to make high current voltage regulators.

Each of these regulators can deliver up to 100mA of output current.

The internal limiting and thermal shutdown features of these regulators make them essentially immune to overload. When used as a replacement for a zener diode-resistor combination, an effective improvement in output impedance can be obtained together with lower-bias current.

FEATURES

- Output Current Up to 100•
- No External Components
- Internal Thermal Overload Protection
- Internal Short-Circuit Limiting
- Output Voltage of 5V, 6V, 8V, 9V, 10V, 12V, 15V, 18V and 24V

ABSOLUTE MAXIMUM RATINGS

Characteristic	Symbol	Value	Unit
Input voltage	V_i	30	V
		35	
		40	
Operating junction temperature	T_{opr}	0 • +150	•
Storage temperature	T_{stg}	-65 • +150	
Soldering temperature and time	T_{sol}	260/10sec	

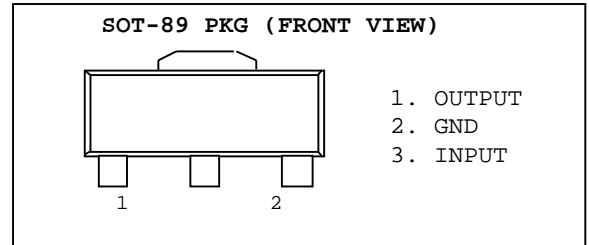
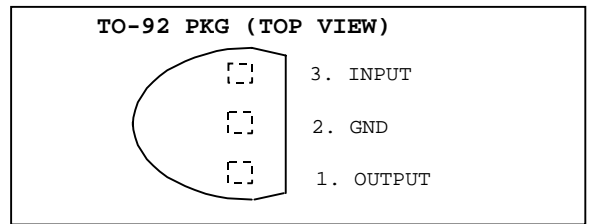

ORDERING INFORMATION

Device	Marking	Package
LM78LXX	LM78LXX	TO-92
LM78L05-A/C	LM78L05-A/C	
LM78L05NF	85N	SOT-89
LM78L05-AF/CF	85A/85C	
LM78L06F~24F	806~824	

HTC

For more information, or to purchase call E.C.C. Inc @ 1-800-214-8769

RECOMMENDED OPERATING CONDITIONS

		Min.	Max.	Unit
Input voltage, V_i	LM78L05 / A / C	7	20	V
	LM78L06	8	20	
	LM78L08	10.5	23	
	LM78L09	11.5	24	
	LM78L10	12.5	25	
	LM78L12	14.5	27	
	LM78L15	17.5	30	
	LM78L18	20.5	33	
	LM78L24	26.5	39	
Output current, I_o			100	•
Operating virtual junction temperature, T_j		0	125	•

TYPICAL APPLICATION

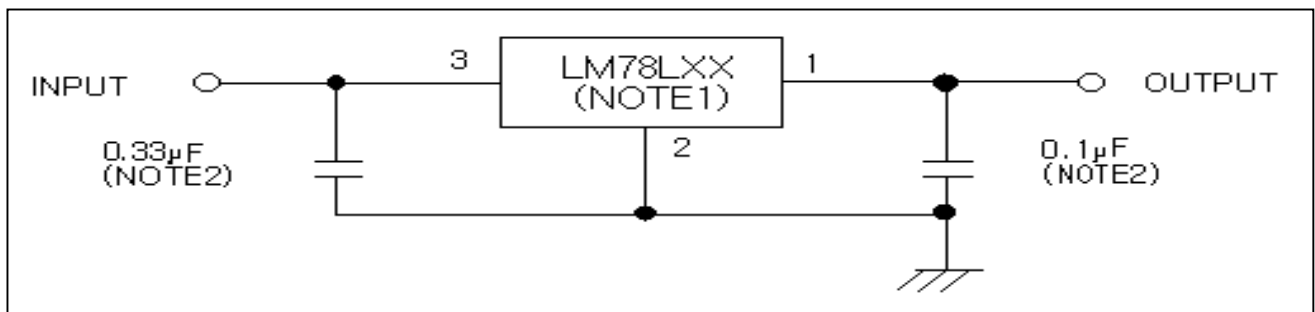

Notes

1. To specify an output voltage, substitute voltage for "XX"
2. Bypass capacitors are recommended for optimum stability and transient response and should be located as close as possible to the regulators.

LM78L05 ELECTRICAL CHARACTERISTICS

 (At specified virtual junction temperature, $V_I=10V$, $I_O=40\mu A$ (unless otherwise noted))

Characteristic	Symbol	Test condition *	Min.	Typ.	Max.	Unit
Output voltage **	V_{OUT}	$25\mu A$	4.8	5	5.2	V
		$1\mu A \cdot I_O \cdot 40\mu A$ $7V \cdot V_I \cdot 20V$	4.75	5	5.25	
		$1\mu A \cdot I_O \cdot 70\mu A$				
Line regulation	Reg line	$7V \cdot V_I \cdot 20V$	25	32	150	%
		$8V \cdot V_I \cdot 20V$		26	100	
Load regulation	Reg load	$1\mu A \cdot I_O \cdot 100\mu A$	25	15	60	%
		$1\mu A \cdot I_O \cdot 40\mu A$		8	30	
Bias current	I_B	$25\mu A$		3.8	6	%
		$125\mu A$			5.5	
Bias current change	ΔI_B	$9V \cdot V_I \cdot 20V$	$0\mu A \cdot 125\mu A$		1.5	%
		$1\mu A \cdot I_O \cdot 40\mu A$			0.1	
Output noise voltage	V_N	$10Hz \cdot f \cdot 100kHz$	25	42		μV
Ripple rejection	RR	$8V \cdot V_I \cdot 18V$ $f=120Hz$	25	41	49	dB
Dropout voltage	V_D		25	1.7		V

Notes

*. Pulse testing techniques are used to maintain the junction temperature as close to the ambient temperature as possible.

Thermal effects must be taken into account separately.

All characteristics are measured with a $0.33\mu F$ capacitor across the input and a $0.1\mu F$ capacitor across the output.

** This specification applies only for DC power dissipation permitted by absolute maximum ratings.

LM78L05A ELECTRICAL CHARACTERISTICS

 (At specified virtual junction temperature, $V_i=10V$, $I_o=40\mu A$ (unless otherwise noted))

Characteristic	Symbol	Test condition *		Min.	Typ.	Max.	Unit
Output voltage **	V_{OUT}		25	4.9	5	5.1	V
		$1\mu A \leq I_o \leq 40\mu A$	0 \leq 125	4.9	5	5.1	
		$7V \leq V_i \leq 20V$		4.9	5	5.1	
Line regulation	Reg line	$7V \leq V_i \leq 20V$	25		5	50	%
		$8V \leq V_i \leq 20V$			3	25	
Load regulation	Reg load	$1\mu A \leq I_o \leq 100\mu A$	25		15	60	%
		$1\mu A \leq I_o \leq 40\mu A$			8	30	
Bias current	I_B		25		3.8	6	%
			125			5.5	
Bias current change	ΔI_B	$9V \leq V_i \leq 20V$	0 \leq 125			1.5	%
		$1\mu A \leq I_o \leq 40\mu A$				0.1	
Output noise voltage	V_N	$10Hz \leq f \leq 100kHz$	25		42		%
Ripple rejection	RR	$8V \leq V_i \leq 18V$ $f=120Hz$	25	41	49		%
Dropout voltage	V_D		25		1.7		V

Notes

*. Pulse testing techniques are used to maintain the junction temperature as close to the ambient temperature as possible.

Thermal effects must be taken into account separately.

All characteristics are measured with a 0.33 μF capacitor across the input and a 0.1 μF capacitor across the output.

** This specification applies only for DC power dissipation permitted by absolute maximum ratings.

LM78L06 ELECTRICAL CHARACTERISTICS

 (At specified virtual junction temperature, $V_i=10V$, $I_o=40\mu A$ (unless otherwise noted))

Characteristic	Symbol	Test condition *		Min.	Typ.	Max.	Unit
Output voltage **	V_{OUT}		25	5.75	5	6.25	V
		$1\mu A \leq I_o \leq 40\mu A$ $8V \leq V_i \leq 20V$	0 • • 125 •	5.7	5	6.3	
		$1\mu A \leq I_o \leq 70\mu A$		5.7	5	6.3	
Line regulation	Reg line	$8V \leq V_i \leq 20V$	25 •		35	175	•
		$9V \leq V_i \leq 20V$			29	125	
Load regulation	Reg load	$1\mu A \leq I_o \leq 100\mu A$	25 •		16	80	•
		$1\mu A \leq I_o \leq 40\mu A$			9	40	
Bias current	I_B		25 •		3.9	6	•
			125 •			5.5	
Bias current change	ΔI_B	$9V \leq V_i \leq 20V$	0 • • 125 •			1.5	•
		$1\mu A \leq I_o \leq 40\mu A$				0.1	
Output noise voltage	V_N	$10Hz \leq f \leq 100kHz$	25 •		46		•
Ripple rejection	RR	$9V \leq V_i \leq 19V$ $f=120Hz$	25 •	40	48		•
Dropout voltage	V_D		25 •		1.7		V

Notes

*. Pulse testing techniques are used to maintain the junction temperature as close to the ambient temperature as possible.

Thermal effects must be taken into account separately.

All characteristics are measured with a $0.33\mu F$ capacitor across the input and a $0.1\mu F$ capacitor across the output.

** . This specification applies only for DC power dissipation permitted by absolute maximum ratings.

LM78L08 ELECTRICAL CHARACTERISTICS

 (At specified virtual junction temperature, $V_I=14V$, $I_O=40\mu A$ (unless otherwise noted))

Characteristic	Symbol	Test condition *	Min.	Typ.	Max.	Unit	
Output voltage **	V_{OUT}		25	7.7	8	8.3	V
		$1\mu A \leq I_O \leq 40\mu A$ $10.5V \leq V_I \leq 23V$	0 • • 125 •	7.6	8	8.4	
		$1\mu A \leq I_O \leq 70\mu A$		7.6	8	8.4	
Line regulation	Reg line	$10.5V \leq V_I \leq 23V$	25		42	175	•
		$11V \leq V_I \leq 23V$			36	125	
Load regulation	Reg load	$1\mu A \leq I_O \leq 100\mu A$	25		18	80	•
		$1\mu A \leq I_O \leq 40\mu A$			10	40	
Bias current	I_B		25		4	6	•
			125			5.5	
Bias current change	ΔI_B	$11V \leq V_I \leq 23V$	0 • • 125 •			1.5	•
		$1\mu A \leq I_O \leq 40\mu A$				0.1	
Output noise voltage	V_N	$10Hz \leq f \leq 100kHz$	25		54	•	
Ripple rejection	RR	$13V \leq V_I \leq 23V$ $f=120Hz$	25	37	46	•	
Dropout voltage	V_D		25		1.7	V	

Notes

*. Pulse testing techniques are used to maintain the junction temperature as close to the ambient temperature as possible.

Thermal effects must be taken into account separately.

All characteristics are measured with a $0.33\mu F$ capacitor across the input and a $0.1\mu F$ capacitor across the output.

** This specification applies only for DC power dissipation permitted by absolute maximum ratings.

LM78L09 ELECTRICAL CHARACTERISTICS

 (At specified virtual junction temperature, $V_I=16V$, $I_O=40\mu A$ (unless otherwise noted))

Characteristic	Symbol	Test condition *		Min.	Typ.	Max.	Unit
Output voltage **	V_{OUT}		25	8.6	9	9.4	V
		$1\mu A \leq I_O \leq 40\mu A$ 12V $\leq V_I \leq 24V$	0 $\leq f \leq 125$	8.55	9	9.45	
		$1\mu A \leq I_O \leq 70\mu A$		8.55	9	9.45	
Line regulation	Reg line	12V $\leq V_I \leq 24V$	25		45	175	%
		13V $\leq V_I \leq 24V$			40	125	
Load regulation	Reg load	$1\mu A \leq I_O \leq 100\mu A$	25		19	90	%
		$1\mu A \leq I_O \leq 40\mu A$			11	40	
Bias current	I_B		25		4.1	6	%
			125			5.5	
Bias current change	ΔI_B	13V $\leq V_I \leq 24V$	0 $\leq f \leq 125$			1.5	%
		$1\mu A \leq I_O \leq 40\mu A$				0.1	
Output noise voltage	V_N	10Hz $\leq f \leq 100kHz$	25		58		%
Ripple rejection	RR	13V $\leq V_I \leq 23V$ $f=120Hz$	25	38	45		%
Dropout voltage	V_D		25		1.7		V

Notes

*. Pulse testing techniques are used to maintain the junction temperature as close to the ambient temperature as possible.

Thermal effects must be taken into account separately.

All characteristics are measured with a 0.33 μF capacitor across the input and a 0.1 μF capacitor across the output.

** . This specification applies only for DC power dissipation permitted by absolute maximum ratings.

LM78L10 ELECTRICAL CHARACTERISTICS

 (At specified virtual junction temperature, $V_I=17V$, $I_O=40\mu A$ (unless otherwise noted))

Characteristic	Symbol	Test condition *		Min.	Typ.	Max.	Unit
Output voltage **	V_{OUT}		25	9.6	10	10.4	V
		$1\mu A \leq I_O \leq 40\mu A$ $13V \leq V_I \leq 25V$	0 • • 125 •	9.5	10	10.5	
		$1\mu A \leq I_O \leq 70\mu A$		9.5	10	10.5	
Line regulation	Reg line	$13V \leq V_I \leq 25V$	25 •		51	175	•
		$14V \leq V_I \leq 25V$			42	125	
Load regulation	Reg load	$1\mu A \leq I_O \leq 100\mu A$	25 •		20	90	•
		$1\mu A \leq I_O \leq 40\mu A$			11	40	
Bias current	I_B		25 •		4.2	6	•
			125 •			5.5	
Bias current change	ΔI_B	$14V \leq V_I \leq 25V$	0 • • 125 •			1.5	•
		$1\mu A \leq I_O \leq 40\mu A$				0.1	
Output noise voltage	V_N	$10Hz \leq f \leq 100kHz$	25 •		62		•
Ripple rejection	RR	$15V \leq V_I \leq 25V$ $f=120Hz$	25 •	37	44		•
Dropout voltage	V_D		25 •		1.7		V

Notes

*. Pulse testing techniques are used to maintain the junction temperature as close to the ambient temperature as possible.

Thermal effects must be taken into account separately.

All characteristics are measured with a $0.33\mu F$ capacitor across the input and a $0.1\mu F$ capacitor across the output.

** . This specification applies only for DC power dissipation permitted by absolute maximum ratings.

LM78L12 ELECTRICAL CHARACTERISTICS

 (At specified virtual junction temperature, $V_i=19V$, $I_o=40\mu A$ (unless otherwise noted))

Characteristic	Symbol	Test condition *		Min.	Typ.	Max.	Unit
Output voltage **	V_{OUT}		25	11.5	12	12.5	V
		$1\mu A \leq I_o \leq 40\mu A$ $14V \leq V_i \leq 27V$	0 • 125	11.4	12	12.6	
		$1\mu A \leq I_o \leq 70\mu A$		11.4	12	12.6	
Line regulation	Reg line	$14.5V \leq V_i \leq 27V$	25		55	250	•
		$16V \leq V_i \leq 27V$			49	200	
Load regulation	Reg load	$1\mu A \leq I_o \leq 100\mu A$	25		22	100	•
		$1\mu A \leq I_o \leq 40\mu A$			13	50	
Bias current	I_B		25		4.3	6.5	•
			125			6	
Bias current change	ΔI_B	$16V \leq V_i \leq 27V$	0 • 125			1.5	•
		$1\mu A \leq I_o \leq 40\mu A$				0.1	
Output noise voltage	V_N	$10Hz \leq f \leq 100kHz$	25		70		•
Ripple rejection	RR	$15V \leq V_i \leq 25V$ $f=120Hz$	25	37	42		•
Dropout voltage	V_D		25		1.7		V

Notes

*. Pulse testing techniques are used to maintain the junction temperature as close to the ambient temperature as possible.

Thermal effects must be taken into account separately.

All characteristics are measured with a $0.33\mu F$ capacitor across the input and a $0.1\mu F$ capacitor across the output.

** This specification applies only for DC power dissipation permitted by absolute maximum ratings.

LM78L15 ELECTRICAL CHARACTERISTICS

 (At specified virtual junction temperature, $V_I=23V$, $I_O=40\mu$ (unless otherwise noted))

Characteristic	Symbol	Test condition *	Min.	Typ.	Max.	Unit
Output voltage **	V_{OUT}	25μ	14.4	15	15.6	V
		$1\mu \cdot I_O \cdot 40\mu$ $17.5V \cdot V_I \cdot 30V$	14.25	15	15.75	
		$1\mu \cdot I_O \cdot 70\mu$				
Line regulation	Reg line	$17.5V \cdot V_I \cdot 30V$	25	65	300	%
		$19V \cdot V_I \cdot 30V$		58	250	
Load regulation	Reg load	$1\mu \cdot I_O \cdot 100\mu$	25	25	150	%
		$1\mu \cdot I_O \cdot 40\mu$		15	75	
Bias current	I_B	25μ		4.2	6.5	%
		125μ			6	
Bias current change	ΔI_B	$19V \cdot V_I \cdot 30V$	0 • • 125 •		1.5	%
		$1\mu \cdot I_O \cdot 40\mu$			0.1	
Output noise voltage	V_N	$10Hz \cdot f \cdot 100kHz$	25	82		%
Ripple rejection	RR	$18.5V \cdot V_I \cdot 28.5V$ $f=120Hz$	25	37	44	%
Dropout voltage	V_D		25	1.7		V

Notes

*. Pulse testing techniques are used to maintain the junction temperature as close to the ambient temperature as possible.

Thermal effects must be taken into account separately.

All characteristics are measured with a 0.33μ capacitor across the input and a 0.1μ capacitor across the output.

** This specification applies only for DC power dissipation permitted by absolute maximum ratings.

LM78L18 ELECTRICAL CHARACTERISTICS

 (At specified virtual junction temperature, $V_I=26V$, $I_O=40\mu$ (unless otherwise noted))

Characteristic	Symbol	Test condition *		Min.	Typ.	Max.	Unit
Output voltage **	V_{OUT}		25	17.3	18	18.7	V
		$1\mu \cdot I_O \cdot 40\mu$ 20.5V $\cdot V_I \cdot 33V$	0 $\cdot \cdot$ 125	17.1	18	18.9	
		$1\mu \cdot I_O \cdot 70\mu$		17.1	18	18.9	
Line regulation	Reg line	20.5V $\cdot V_I \cdot 33V$	25		70	360	%
		22V $\cdot V_I \cdot 33V$			64	300	
Load regulation	Reg load	$1\mu \cdot I_O \cdot 100\mu$	25		27	180	%
		$1\mu \cdot I_O \cdot 40\mu$			19	90	
Bias current	I_B		25		4.7	6.5	%
			125			6	
Bias current change	ΔI_B	22V $\cdot V_I \cdot 33V$	0 $\cdot \cdot$ 125			1.5	%
		$1\mu \cdot I_O \cdot 40\mu$				0.1	
Output noise voltage	V_N	10Hz $\cdot f \cdot 100kHz$	25		82		%
Ripple rejection	RR	21.5V $\cdot V_I \cdot 31.5V$ $f=120Hz$	25	32	36		%
Dropout voltage	V_D		25		1.7		V

Notes

*. Pulse testing techniques are used to maintain the junction temperature as close to the ambient temperature as possible.

Thermal effects must be taken into account separately.

All characteristics are measured with a 0.33 μ capacitor across the input and a 0.1 μ capacitor across the output.

** . This specification applies only for DC power dissipation permitted by absolute maximum ratings.

LM78L24 ELECTRICAL CHARACTERISTICS

 (At specified virtual junction temperature, $V_I=32V$, $I_O=40mA$ (unless otherwise noted))

Characteristic	Symbol	Test condition *		Min.	Typ.	Max.	Unit
Output voltage **	V_{OUT}		25•	23	24	25	V
		$1••I_O•40•$ $26.5V•V_I•39V$	0• • 125•	22.8	24	25.2	
		$1••I_O•70•$		22.8	24	25.2	
Line regulation	Reg line	$26.5V•V_I•39V$	25•		95	480	•
		$29V•V_I•39V$			78	400	
Load regulation	Reg load	$1••I_O•100•$	25•		41	240	•
		$1••I_O•40•$			28	120	
Bias current	I_B		25•		4.8	6.5	•
			125•			6	
Bias current change	$•I_B$	$28V•V_I•39V$	0• • 125•			1.5	•
		$1••I_O•40•$				0.1	
Output noise voltage	V_N	$10Hz•f•100kHz$	25•		82		•
Ripple rejection	RR	$27.5V•V_I•37.5V$ $f=120Hz$	25•	30	33		•
Dropout voltage	V_D		25•		1.7		V

Notes

*. Pulse testing techniques are used to maintain the junction temperature as close to the ambient temperature as possible.

Thermal effects must be taken into account separately.

All characteristics are measured with a 0.33• capacitor across the input and a 0.1• capacitor across the output.

** . This specification applies only for DC power dissipation permitted by absolute maximum ratings.